



# LPSSHUT-4 (SR4)

## Steel Security Shutter



## Installation Instructions

## Operation & Maintenance Instructions

Please follow these installation instructions carefully when installing the shutter!  
This booklet should be left with the product for future reference.



**Certificate No. 931**

# Contents

<b>Page</b>	<b>Title</b>	<b>Step No.</b>
	<b>Installation Instructions</b>	-
3	Installing Security Rated Products	-
4	Declaration of Incorporation	-
5	Declaration of Performance	-
7	General Description	-
7	Safety Notice	-
8	Taking delivery and checking all parts	1
8	Fixing the angles	2
10	Fitting the end plates and motor barrel	3
11	Curtain installation	4
12	Attaching guide channels	5
12	Bullet locks	6
12	Threshold strip and transverse lock (3m+ wide only)	7
15	Motor operation	8
17	Fixing the canopy	9
17	Rules for Overrides, Control Panels, and Switches	10
18	Locking Fail-safes Wiring Diagram	11
19	Final inspection	12
19	Dismantling	
20	Notes	-
<b>21</b>	<b>Operation &amp; Maintenance Instructions</b>	-
22	1. Service Schedule	-
22	2. Locking Systems (SR4)	-
23	3. Electrically Operated Products	-
24	3.1.1 Hold to Run Switches	-
25	4. Maintenance	-
26	5. Service and Repair Record	-

## Installing Security Rated Products

The UKRS LPSSHUT-4 (SR4) has been tested by the Loss Prevention Certification Board and has been certified as reaching SR4 level (LPS 1175 Standard (Issue 7)). The shutter has SR4 certification for steel, reinforced concrete and reinforced masonry substrates. To ensure that individual and custom-made shutters are the same as those which have been tested and certified, installers must carefully read and follow this manual of Installation Instructions.

Please pay particular attention to the following before beginning the installation:

1. For SR4 shutters the following substrates are alone permissible: **Mild Steel** of a wall thickness of at least 5mm (the fixings can be screwed or bolted in with the approved fixings); **Concrete** beams will be reinforced with the standard industry method; **Brick** will be reinforced with the standard industry method. Other substrates are not permitted.
2. The substrate (i.e., masonry, steel, etc.) to which the shutter is to be fixed must be level, and variation from the level vertical face of the substrate must not constitute more than 10% of the total level face of the substrate. Use cement to correct any irregularities on the opening face of brick or concrete where possible.
3. The LPSSHUT-4 must only be fitted to the internal face of an opening. The product is not tested or approved to be fitted either in the reveal or externally.
4. The supplied fixings alone must be used to attach the door to the substrate. The fixings are essential to the overall security level of the finished installation. For information on fixings, see page 10.
5. Locking methods for the shutter must be installed. The Bullet Locks and Ground Locks (where appropriate) must be in place if the Security Rating is to apply. Therefore, to ensure that the locks are used when necessary, and disengaged when the door is operating, end users require training in the use of the locks and failsafe isolators. It is the responsibility of the installer to, as a minimum, hand over this document, explaining the location and function of locking mechanisms on shutters.

**If any problems arise during the installation of this product regarding the above, or regarding any other matter, please contact UK Roller Shutters and Garage Doors Ltd for advice or assistance on:**

**Tel: 0 (44) 1384221743**

**[sales@ukrollershutters.co.uk](mailto:sales@ukrollershutters.co.uk)**

# Declaration of Performance

No. LPSSHUT-4

Declared Performance

<b>Essential Characteristics</b>	<b>Performance</b>	<b>Harmonised Technical Specification</b>
Geometry of glass	NA	BS EN 13241-1:2003+A1:2010
Mechanical Resistance	Pass	
Water tightness	NPD	
Release of dangerous substances	None	
Resistance to wind load – Test Pressure	Class 5	
Thermal resistance	NPD	
Air permeability	NPD	
Durability of water tightness, thermal resistance and air permeability	NPD	
Safe opening (i.e., Safety Brake)	Pass	
Operating forces (i.e., Safety Edge)	NA	

9. The performance of the product identified in points 1 and 2 is in conformity with the declared performance in point 8. This declaration of performance is issued under the sole responsibility of the manufacturer identified in point 4.

## **General Description**

Installation type: Face Fix only

Substrates: Reinforced brick work,  
reinforced concrete,  
mild steel (5mm wall min)

Min Width: 1000mm

Max Width: 7000mm

Min Height: 1300mm

Max Height: 5000mm

Locking method: 1. Bullet locks (H75)  
2. Transverse ground locking system (opening width =>3m)

Curtain weight: 100kg per m<sup>2</sup> (approx.)

Guide Channel

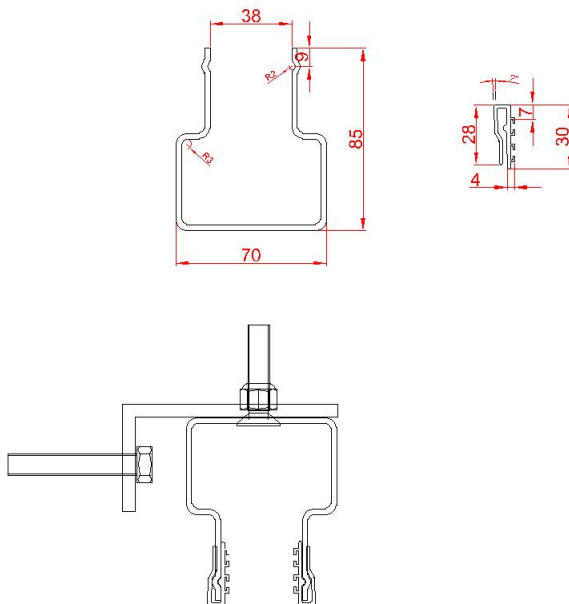

Slat / curtain

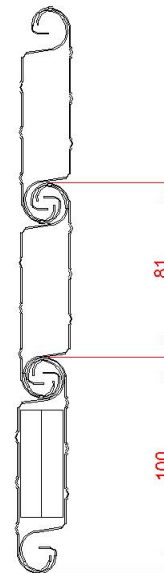

## **SAFETY NOTICE**

The curtain roll is heavy and awkward to handle. It is recommended that this shutter is installed after a period of careful planning; installation should be carried out by persons with sufficient experience of installing industrial shutters. It is not advised to carry shutter slats manually into location; rather, mechanical carrying aids should be used where possible. Working at height should not be carried out without appropriate fixed or mechanical equipment.

Large shutters will require a safe system of work detailing how installers approach individual tasks. It is highly advised that a detailed plan or method statement is devised before beginning work on shutters. Work at height, and excessive manual handling risks should be controlled or avoided.

UK Roller Shutters and Garage Doors Ltd will be glad to assist in the planning of the installation of the shutter; delivery arrangements of the shutter can be agreed with UK Roller Shutters and Garage Doors Ltd at time of order, including an agreement about how the parts with most size and weight are to be delivered.

The LPSSHUT-4 SR4 Elite shutter uses a heavy gauge curtain slat weighing 37kg per meter square. In addition, reinforcement bars are concealed inside the slats, raising the curtain weight to 100kg per meter square.

Only trained and properly equipped persons should attempt to install and commission the LPSSHUT-4 Elite SR4 shutter.

Single or three-phase power required for the motor should be provided by a qualified electrical engineer.

## **STEP 1 – TAKING DELIVERY AND CHECKING ALL PARTS**

Please check that the shutter is the correct size and all component parts are present.

You should have:

- A) Shutter curtain
- B) Installation kit, including approved fixings
- C) Shutter Guide Channels
- D) Shutter Support Angles and Protection Angles
- E) Tube (with top rail bolted on)
- F) Motor
- G) Galvanised steel canopy (where ordered)
- H) Any controls and switches, including safety devices and isolators

## **STEP 2 – FIXING THE ANGLES (Support Angles and Protection Angles)**

UK Roller Shutters and Garage Doors Ltd will supply the approved fixings for installation of the Protection and Support angles. Contact the office on the telephone number on page 3 with any problems

### **Packing off Fixing Angles / Box Sections**

Ensure that the substrate is regular, such that packers are never required. This requirement should pose no problem when fixing to steel or aluminium; but brickwork or concrete should be treated with cement prior to fixing (the gaps which usually occur between courses of bricks do not need to be filled in).

Ensure that the site is clear and that the fixing surfaces are free from loose plaster and masonry. Ensure that the opening has no irregularities which might snag the curtain. You are advised to double check the measurements of the opening before beginning work.

- 1) Refer to paperwork for sizes and location of the shutter before beginning work
- 2) The back of the **Support Angles** must be fitted 100mm set back from opening; See Table (4) below for fixing type. Angles are pre-drilled for locations of fixings. Note that, because they are fixed to the Angle, the End Plates are usually fixed at the same moment as the Support Angle.



- 3) **Protection Angles** are fitted flush with the opening; for the Protection Angles - M16 10.9 grade screws must be used into steel; High Tensile anchor bolts will be used into brick or concrete. See Table (4) below.

4)

Substrate	Fixing (Support Angle)	Fixing (Protection Angle)	Distances
Steel work (5mm min)	M10 (8.8 grade). use Nyloc nut, or tap into the steel	M16 (10.9 grade); use Nyloc nut, or tap into the steel	100mm top and bottom of angle, then max. 400mm between
Brick (reinforced)	M10 expansion bolt High Tensile	M16 expansion bolt High Tensile	As for steel
Concrete (reinforced)	As for brick	As for brick	As for steel



### **STEP 3 – FIT THE END PLATES AND MOTOR BARREL**

- 1) End Plates should be fixed into the substrate bearing in mind the weight of the entire End Plate assembly – which includes Curtain and Tube. **Shearing and Tension pull-out forces** on fixings must be calculated (UK Roller Shutters and Garage Doors Ltd can advise on this), and fixing no.s and sizes for the End Plates worked out. The stability of the substrate should be borne in mind when planning the installation; large shutters must be fixed to an appropriately stable support. In circumstances where the shutter will be sited on particularly weak or un-reinforced brick / concrete, a steel frame may be required and should be fabricated to spread the load (again, calculations for steel load bearing may be required).

The SR4 shutter End Plates are attached to the Support Angles; securely fixing the Support Angles will also fix the End Plates; further fixings can be put through into the substrate if required.

- 2) When the Support Angles and top End Plates are secure, install the Tube and Motor into the End Plates. This step can be achieved both for a Tube without the Curtain attached, or with the Tube and Curtain in one unit. The Tube / Curtain & Tube should be lifted into place with a fork lift truck or other mechanical lifting aid.
- 3) When the Tube is located centrally into the End Plates, tighten the bearing plates with the supplied nuts and bolts. Bolts should be snug tight with ordinary spanner.
- 4) Slide the Motor onto the shaft and fix in place with supplied bolts.

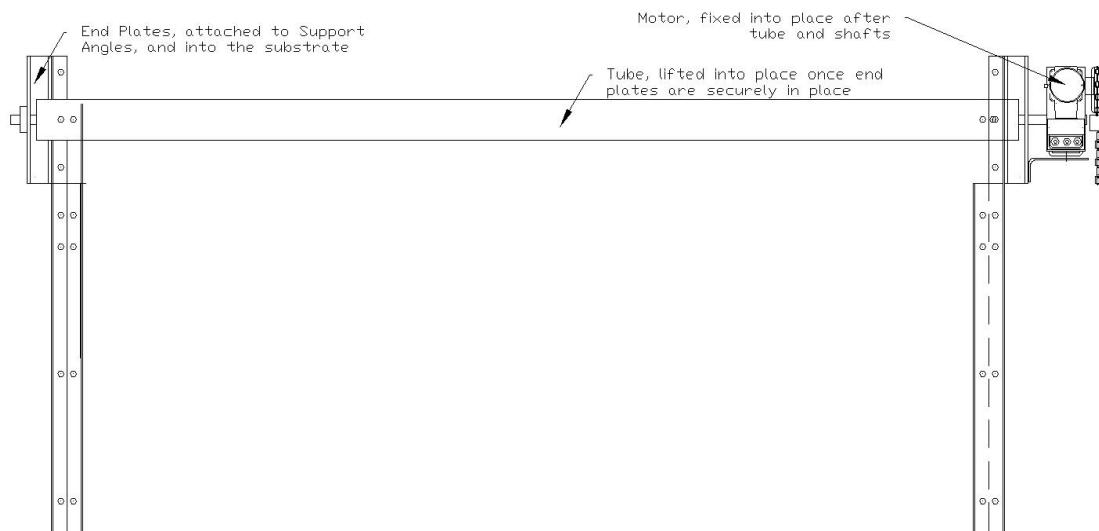

## **STEP 4 – CURTAIN INSTALLATION**

- 1) For the LPSSHUT-4 the curtain should be installed as a single unit.  
To install as a single unit, a fork lift truck must be employed, often with the Tube enclosed inside the curtain. Before planning a lift with a Fork Lift Truck, ensure the weight of the Curtain and Tube is within the limits assigned to the FLT.
- 2) Secure the Curtain roll to the FLT forks. Repeat Step 3 (above) but with Curtain wrapped around the Tube.

The following describes the composition of the curtain:

- 1) The top eight slats are **not** reinforced. These slats are 18swg double skin without the reinforcing bars; they are therefore easier to move and to work on.
- 2) Full reinforcement bars are inside no.s: 1, 3, 5, etc., all odd numbers to fill the entire opening height.
- 3) Slat no. 2 has 2no. 600mm bars at either end.
- 4) All slats are end locked with 2no. 4.5x16mm aluminium rivets; even number slats employ aluminium, odd number slats nylon endlocks.

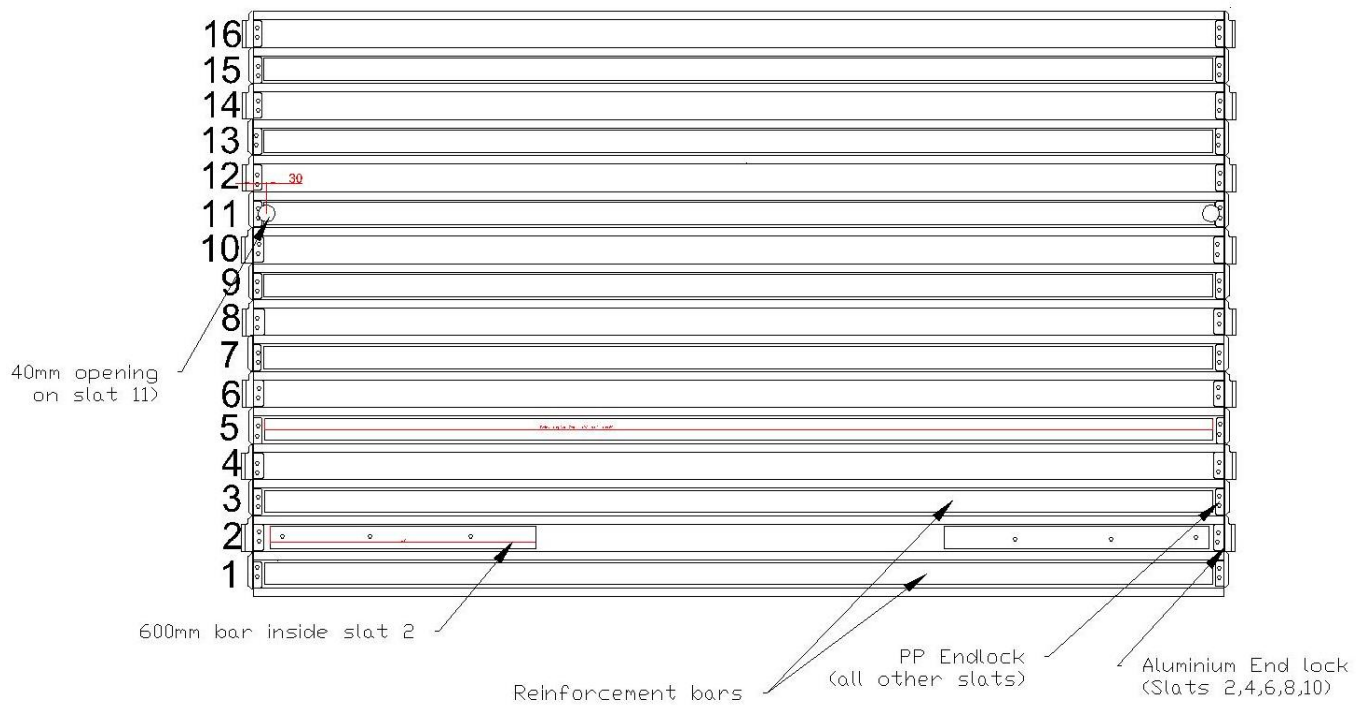

## **STEP 5 – ATTACH THE GUIDE CHANNELS**

- 1) Once the Curtain is attached, fix the Guide Channels in place through the pre-drilled holes which lead through the Support Angle and the Guide channels. Send the shutter in the upward position allowing access to fix the Guides to the Angles using the supplied 40mm M10 c/sunk screws and nyloc nut: 100mm from top and bottom of the guide channel, maximum of 300mm in between distance.

## **STEP 6 – BULLET LOCKS**

- 1) All Elite LPSSHUT-4 shutters have bullet locks fitted. Attach the Bullet Lock Support Plate to the Support Angles. The Support Angles are supplied with tapped apertures to admit the Bullet Lock Support Plate; the Bullet pins should pass through the 11<sup>th</sup> slat.

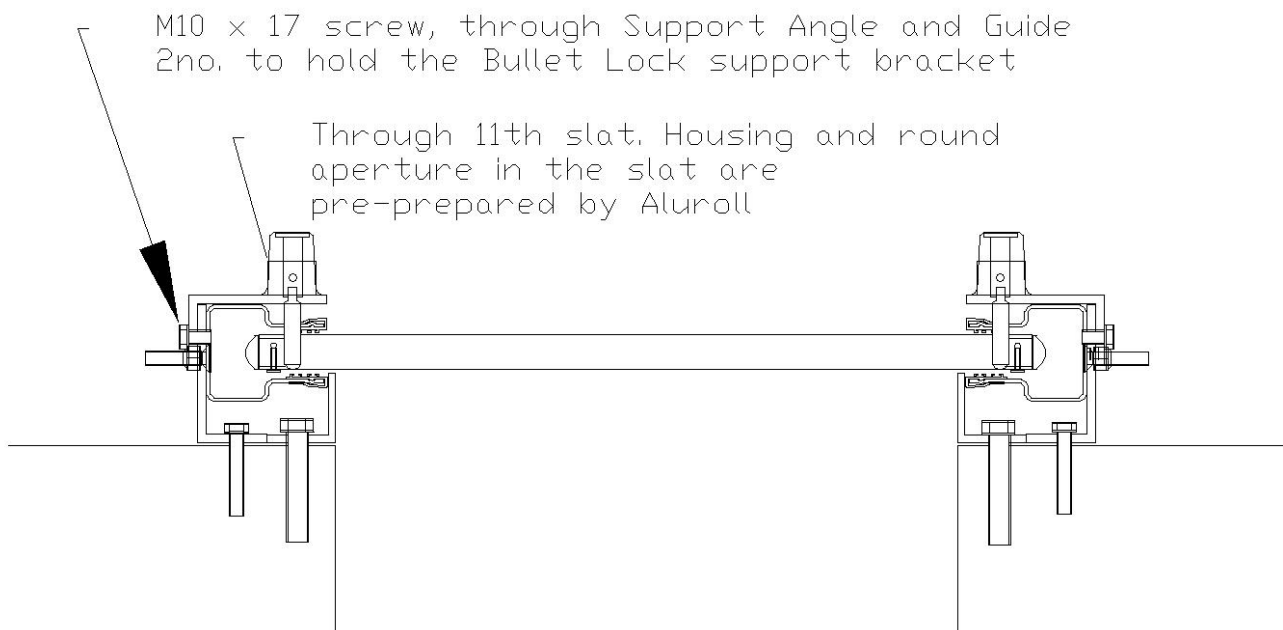

## **STEP 7 – THRESHOLD STRIP AND TRANSVERSE LOCK (= > 3M WIDE ONLY)**

- 1) SR4 LPSSHUT-4 Shutters of 3m wide and over require a threshold strip and a movable transverse locking system on the bottom slat. The lock is pre-installed onto the bottom slat. The locking hooks line up with a threshold when the lock is in the 'Open' position.
- 2) Place the Threshold inside the opening; the Threshold is to be located centrally and touching the ends of the Protection Angles which are flush with the opening.
- 3) Check the alignment of the Threshold with the locking Hooks before proceeding.
- 4) Drill 16mm holes through the Threshold into the ground (must be concrete or similar) with 16mm masonry bit; fix M16 anchor bolts through the Threshold into the drilled holes.

Note: the Threshold and Lock system will not work unless the Threshold is entirely level. If the ground is uneven, then the Threshold will naturally follow the unevenness and affect the work of the Hooks. It may be necessary to use packers to level the ground out for the Threshold – or, alternatively, to use concrete / cement to level the ground prior to installation.

- 5) Check that the Locking Hooks of the bottom slat and the Threshold strip apertures line up on the shutter. The Hooks should move freely back and forth under control of the Locking Bar handle. Any problems will most often be due to an un-level or off-center threshold.

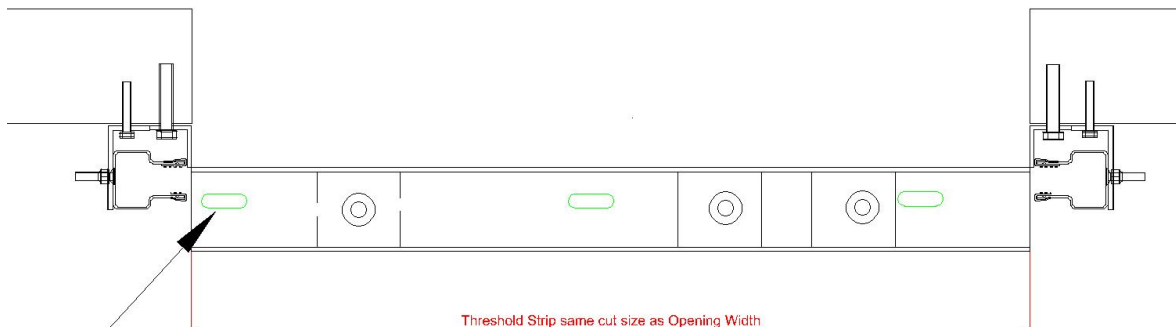

LHS hook will be close to edge, as shown

- 6) The Movable Eyelet must line up with the Fixed Eyelet for the Padlock. The Fixed Eyelet Assembly is pre-located and fixed in place with M10x17mm machine screws; likewise, the Movable Eyelet Assembly is welded to the Locking Bar; 17mm aperture on both Assemblies will line up when the Locking Bar is in the Closed position. Ensure that this is the case and that the Padlock supplied with the shutter is operable. Do not use any but the supplied FF Padlock.

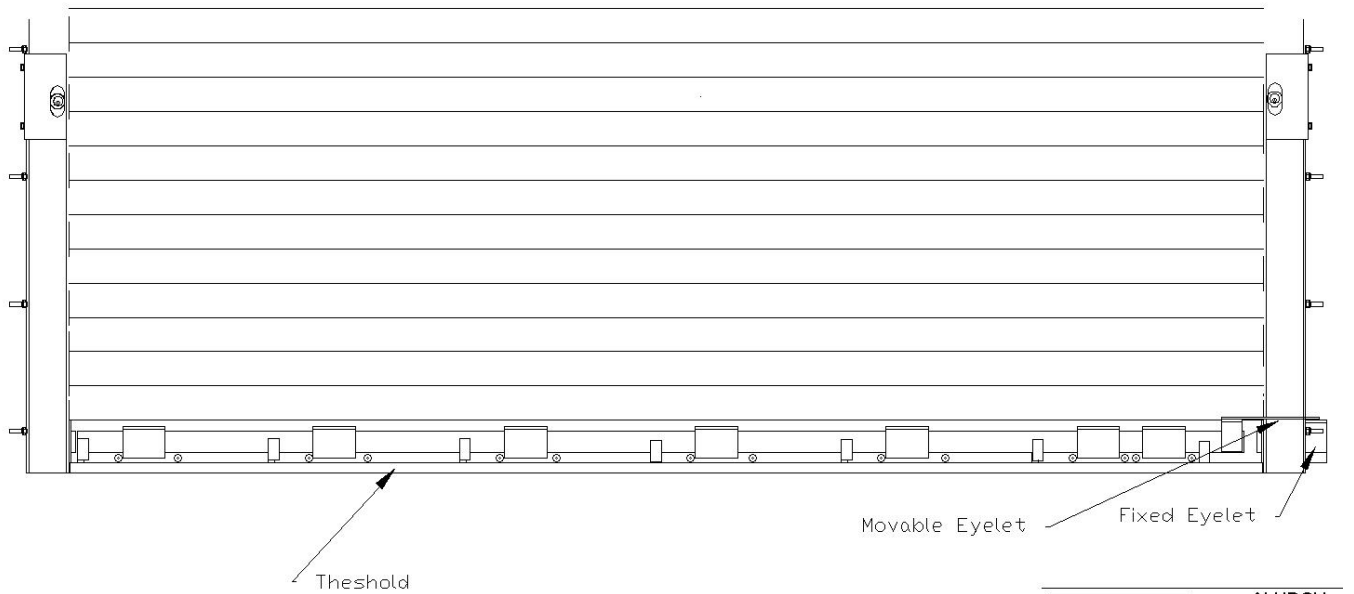

## **STEP 8 – MOTOR OPERATION**

### **Locks**

Do not use the motor while the Bullet Locks or the Transverse Locking Bar are in the locked position. Use a Bullet Lock Isolator for the bullet lock pins, and a Ground Lock Isolator for the padlock, thereby ensuring that the motor will not operate unless the pins and padlock are fully disengaged. The bottom slat Transverse Locking Bar (shutters over 3 meters in width only) is equipped with a position Micro Switch with roller follower; this should be fully operational at time of final commissioning. The Micro Switch will ensure the Hooks are in the open position before motor operation is possible.

### **Tube Motors**

For certain small shutters, a Tubular Motor will be appropriate; Tubular Motors run off a 230V supply and should be run through a control panel allowing the Isolator and switch to be volt-free / 24V.

### **Direct Drive Motors**

400V x 3 phase power is appropriate for Direct Driver motors; it should be supplied via a 5-pin socket 1m away from the Motor control panel.

### **Operation**

The SR4 Shutter is 'dead man' only. Remote control operation is not permitted due to the nature of the bottom edge of the shutter – which does not allow for a 'safety edge' type restraint on operating forces.

### **A. Motor limit setting: Tube motor**

1. Site the push button station at a suitable height and location. (Final wiring should be co-ordinated with the site / customer requirements).
2. Fix the mains outlet at a suitable height and location
3. Secure the cabling, to prevent impeding the door operation.
4. The motor will have screw type limit switches. A straight line arrow pointing to the back of the shutter, or to the top of the shutter, will be found next to one of the screw limits. This is the Door Close limit switch. Turn the screw in the + (plus) direction to make the door close lower down. The – (minus) direction will make the door stop short.

The straight arrow pointing next to the other screw is the sign for the Door Opening limit; turn in the plus direction for more travel of the curtain upward, and vice versa.

It is usually necessary to turn both screws in the '-' direction until the Stop point is within the opening, meaning that the shutter stops short of the bottom and top. Once you have found the Stop position for both up and down directions, it is necessary only to add '+' to the door travel, until it stops at the exact position required.

## **B. Limit Setting: Direct drive motors**

A range of 3-phase motors are used for various applications. Limit setting processes will depend on the kind of motor employed. See the installation instructions supplied with the motor. Direct Drive motors by GfA or MFZ make use of control panels into which the No. of Turns / Limit Positions can be programmed into the control panel.



## **STEP 9 – FIXING THE CANOPY**

1. Situate the Canopy so that it sits with no uneven overhang.
2. The Canopy has slots pre-drilled through which it should be fixed to the substrate and the End Plates.
3. An aperture for the override eyelet should be drilled / cut out in the case of Tubular motors.
4. Using the apertures in the canopy, fix the top back of the Canopy into the substrate, and to the endplates.
5. The Canopy is not integral to the overall Security Rating of the shutter and is an optional item to suit the needs of the end user.

## **STEP 10 –RULES FOR OVERRIDES, CONTROL PANELS, AND SWITCHES**

### **Override systems and security shutters**

There is no risk of override systems being used by an attacker; therefore, considerations of user-safety alone determine whether the override chain (for 3 phase motors), or the override handle (for single phase tube motors), should be left near to or on the motor system.

### **Control Panels**

Controls panels do not represent a risk in terms of being used by an attacker when they are sited inside the secure side of an opening. A range of switches are available. (Remote control systems should not be fitted with the UK Roller Shutters and Garage Doors Ltd SR4 Elite shutter. Wireless and fixed-in-place key pads are acceptable since these ensure operator is in view of the shutter leaf). Key switches and control panels are supplied with dedicated installation instructions.

### **Externally mounted switches**

The approved SR4 externally mounted switch is limited to the Key Pad – a remote control or wired switch requiring a memorised key pad code. (Instructions supplied with the key pad). The Key Pad will only operate the shutter when the correct code has been input. ***Other types of switch must not be used on the attack side of an opening.***

## **STEP 11 – LOCKING FAILSAFES WIRING DIAGRAM**

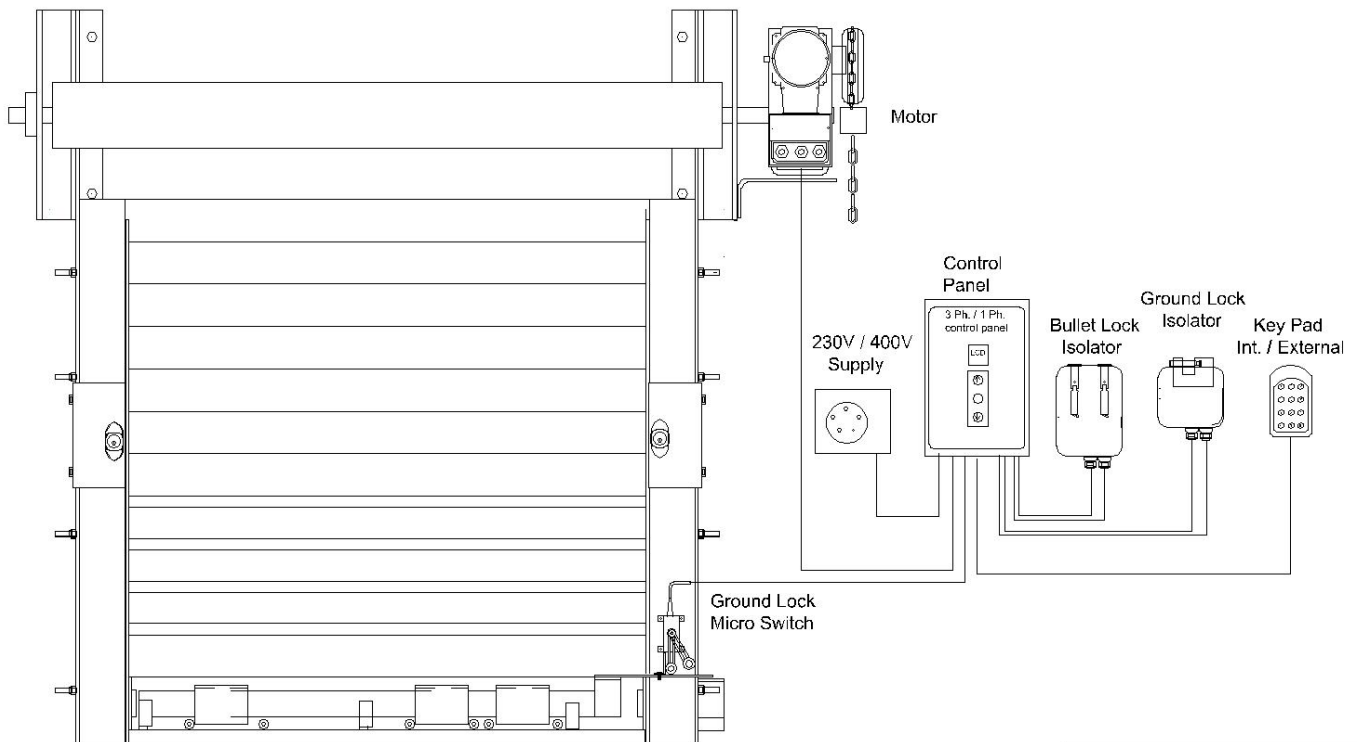

### **Notes**

1. The Ground Lock Isolator and Ground Lock Micro Switch are not required on shutters under 3000mm wide (opening width).
2. See instructions with the particular item for integration with the Control Panel.

## **STEP 12 – FINAL INSPECTION**

After connecting the motor and control, a test of the proper operation of the roller shutter must be carried out. When closing and opening the door ensure that no hitches or interferences occur. If unexpected or loud noises occur, or the door seems to jam, the motor must be stopped immediately. Check whether the Guide Channels are seated correctly and if the Tube is level. Check that the slats enter the Guide properly. If none of these checks explains the failure, the manufacturer of the product should be contacted.

Check that the Transverse Lock operates smoothly and that the Fixed and Movable Eyelets meet properly to admit the Padlock. Check that the motor limits have been set so as to allow smooth operation of the Bullet Locks.

It is highly advised that the Bullet Lock Isolator (and Ground Lock Isolator with Micro Switch roller follower mechanism, where appropriate) is installed to ensure that the shutter is not operated while in the locked condition. **Operation of the shutter with any of the locks engaged may permanently damage the shutter and/or motor.**

## **DISMANTLING**

1. Roll the shutter Curtain up around the Tube.
2. Turn-off the control and motor, and turn-off the current supply.
3. Dismantle the wiring so that the electronic components, motor and safety brake, are no longer connected to other components.
4. Use a Fork Lift Truck or similar to adequately support the Curtain and Tube from beneath: establish the weight of the load and the load restrictions on the lifting gear.
5. The Curtain should be attached to the lifting gear with ratchet straps or similar restraints.
6. While the Curtain and Tube are sustained and unable to move, release the nuts attaching the motor and bearings to the End Plates. The Curtain and Tube/Shafts can now be removed from the End Plates. Lower these to the ground under control.

7. Remove the Guide Channels; then the Support Angles from the edges of the opening. Working at Height equipment should be used for long duration work. Lifting equipment should be employed to allow the Support Angles and End Plates to be lowered under control.

**NOTES:**

# LPSSHUT-4 Elite SR4

## Operating & Maintenance Instructions

### Electrically Operated Roller Shutters

#### 1. General Instructions

#### 2. Operating Instructions

##### 2.1 Electrically Operated Products

- a). Hold To Run Switches
- b). Remote Control
- c). Manual Overrides

#### 3. Maintenance

#### 4. Service & Repair Record

Date of Installation:
Installation By:
Contact Details:

To ensure compliance with the Machinery Directive this document must be retained by the owner of the Door and held for future reference.



## **1. Introduction – Service Schedule**

Your newly installed product should give you many years of trouble-free service. The shutter has a high Security Rating (level 4) and several complicated moving parts; it should be serviced by a professional shutter-maintenance organization every 12 months. UK Roller Shutters and Garage Doors Ltd Ltd can be contacted for information on an approved service organisation.

In order to ensure proper operation as a Security Rated product, and to prolong the life of your shutter, as well as to reduce the likelihood of problems, please pay close attention to the following information.

## **2. Locking Systems (SR4)**

The SR4 Elite LPSSHUT-4 has a single locking system across all models – the Bullet Lock system; and an additional locking system for shutters 3 meters wide and over – the Transverse Lock system. An additional Micro Switch prohibits operation until the Lock Bar has been moved to the extreme left hand side.

### **2.1.1 The Bullet Lock system**

All SR4 shutters use the Bullet Lock system. When the shutter is in the Closed position, the Bullet Pins should be inserted into the Bullet Lock Housings on the Guide Channels. The shutter is not completely secure unless the Pins are in place inside the Housings.

The Pin should be inserted into the Housing only when the shutter is completely closed and has reached its lower limit position. The Pin will thereby engage with the 11<sup>th</sup> slat of the curtain from the ground.

It is important to remove both Bullet Pins before operating the shutter to raise and move it to the Open position; if the Bullet Lock Isolator is properly installed, then the Pins should be removed from the Housings and inserted into the Isolator before any possible operation.

### **2.1.2 The Transverse Lock Ground Anchor system**

Shutters over 3 meters in width (opening size) use a Ground Anchor Transverse Lock system which holds the shutter down firmly across the whole width. This works in unison with the Threshold between the Guide Channels.

When the shutter descends to the Closed position, the Transverse Lock Hooks must be pulled to the extreme Right Hand Side. The Hooks insert themselves into the Threshold when the shutter is entirely closed; the operator must then

pull the Transverse Lock to the extreme Right Hand Side, until the hooks are fully engaged (approx. 20mm of travel); after this, the shutter Padlock can be slipped through the Fixed and Moving Eyelets of the Transverse Lock.

It is important to remove the Padlock before operating the shutter to raise and move it to the Open position. If the Ground Lock Isolator box is properly installed, the shutter will not operate until the Padlock has been inserted into the Isolator.

### **2.1.3 The Micro Switch for the Lock Bar**

Shutters over 3 meters in width (opening size) use a Ground Anchor Transverse Lock system which holds the shutter down firmly across the whole width. This works in unison with the Threshold between the Guide Channels. If the Lock Bar is at the extreme right hand side the Micro Switch attached to the bottom of the right hand side Guide Channel will not allow operation of the shutter. Only when the Locking Bar is at the left hand side will the Micro Switch flip to allow the Motor to operate.

## **3. Electrically Operated Products**

Only operate your shutter when it is in view, making sure it is not obstructed. Ensure the curtain is running in the Guide Channels and that you and any other persons stand clear of the Curtain and keep hands etc. away from moving parts. **Security Rated products have locks which must be put in place at the time of closing; they must be taken away from their place before opening.** The shutter is not secure to the SR4 level unless all installed locks are engaged.

### 3.1.1 Hold To Run Switches

#### Hold To Run Rocker Switch

#### Hold To Run Key Switch

- Make sure all windows and doors which the shutter conceals are closed
- If your shutter contains any manually operated locks – these must be disengaged before you operated the shutter (failure to do so will damage the motor within the shutter).
- Turn / Press the switch in desired direction. The installed switches are momentary, therefore the operator must be present when opening and closing, with all openings in view.
- It is very important that the motor completes its pre-set rotation and the motor stops when closing and opening. The motor locks the shutter only when fully closed, so be sure the curtain is fully down. The motor must stop on its pre-set limits in the open position; this is so that there is an acceptable amount of unbalanced force on the shutter Motor.

<b>TROUBLE SHOOTING</b>		
<b>Fault</b>	<b>Cause</b>	<b>Solution</b>
<b>The shutter/door fails to operate when the button is pressed / key is turned</b>	1. There has been a power failure 2. The wrong direction has been selected on the control equipment. 3. The thermal trip in the motor may have activated if the door has been operated several times recently	1. Wait for power to come back on or operate the shutter/door with the manual override if installed. 2. Select the correct direction. 3. Allow the motor to cool for approximately 30 minutes before attempting to operate the shutter/door again.
<b>The shutter / door stops before fully opening or closing, or fails to stop when reaching its final open or closed position.</b>	The limits in the motor have failed to operate or may not have been set correctly.	Contact your installer.



## **4. MAINTENANCE**

**SERVICE OF THE SHUTTER BY AN APPROVED INSTALLATION / SERVICE ORGANISATION SHOULD BE CARRIED OUT EVERY 12 MONTHS.**

**CAREFUL USE OF YOUR SHUTTER/DOOR IS THE BEST WAY TO AVOID MAINTENANCE OR REMEDIAL WORK**

Your shutter/door is low maintenance. The shutter should be wiped with a damp cloth and a mild detergent to remove any excessive dirt/grime in order to maintain its prime appearance and to reduce the risk of the surface being damaged. This must be done more frequently in a salt air environment.

Marks on the paint finish can be cleaned with many types of car polish. Chips in the paintwork should be touched up to prevent corrosion of the metal.

**The power to the shutter should be isolated before washing or repairing the paintwork.**

The motor and curtain have been designed to be lubrication free; do not oil or grease the guide rails. Ensure no foreign items are collected in the Guide Channels, i.e. stones, sticks, paper etc.

### **Additional information for electrically operated products**

The shutter should run smoothly and easily since the motor is not designed to overcome problems of a badly running or damaged shutter leaf. If necessary contact your approved installer for repair.

The motor should stop on the limits and not over-run (indicated by buzzing) when the door hits the floor or the open-stops at the top of the guide channels.

Always isolate the power before attempting to make any adjustments or repairs. Untrained operators are advised to contact an approved installer.

### 5. SERVICE AND REPAIR RECORD

<b>Date work carried out:</b>
<b>Work carried out:</b>
<b>Work performed by - Sign</b>
<b>Print</b>
<b>Company Name:</b>

<b>Date work carried out:</b>
<b>Work carried out:</b>
<b>Work performed by - Sign</b>
<b>Print</b>
<b>Company Name:</b>