

GLV-INS77

Applications

Commercial sites requiring large aperture coverage and improved insulation properties. High speed motor option available for rapid rise / fast action opening and closing when in conjunction with appropriate sensory peripherals. Suitable for internal or external face or reveal fit.

Curtain Slat

Double skinned polyester powder coated 77mm slat with polyurethane foam insulating core.

Finish: Galvanised as standard. Powder coating and Polycoat laminated finish available on request.

Profile Height: 77mm
 Weight per m²: 10.6kg
 Maximum Width: 8000mm
 Maximum Area: 21m² (tubular)
 42m² (outboard)

Slat U-Value: 2.4 W/m²K
 Resistance to wind load: Class 5 at 7m

Housing

Manufactured from 0.5mm galvanised steel sheet with steel end plates.

Finish: Galvanised as standard. Powder coating available on request.

Guide Height (mm)	Plate Size (mm)	Motor
2459	305	Tubular
3500	355	Tubular
5000	400	Tubular
4000	400	Outboard
6000	450	Outboard

Plate sizes shown as a guide only and may vary. Outboard motors will generally exceed the given plate size.

Guide Channels

Galvanised steel guide channels with brush seal. Width of 65mm as standard; 85mm wind guides and windlocks available. The guide channels are bolted to fixing angles or box section to suit the application.

Finish: Galvanised as standard. Powder coating available on request.

Bottom Slat

Extruded aluminium bottom slat with weather seal.

Operation

Electric: Single phase tubular, three phase outboard or high speed three phase outboard motor, with push button control. Numerous options such as group or remote control operation available as required. Manual override facility as standard. Safety peripherals (i.e., safety edge, photo-electric cell, etc.) will be required for automatic closing or high-speed operation.

CE compliant to all applicable directives and regulations.

Front Face

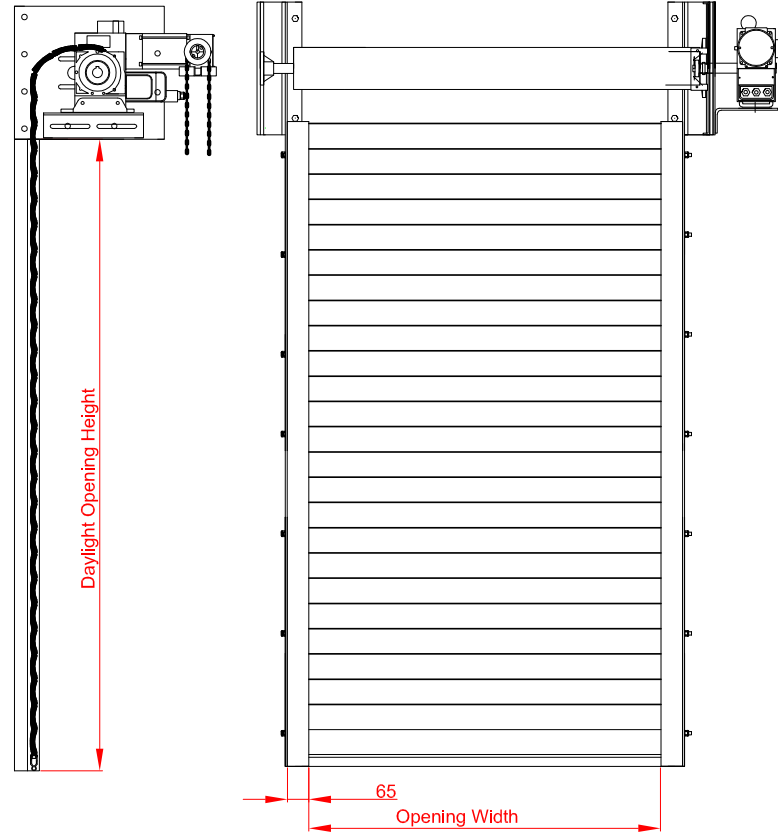

Fixing Detail

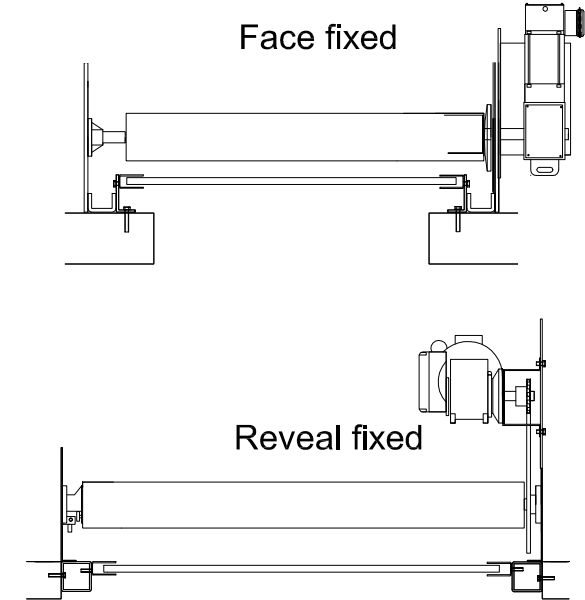

Guide Channels

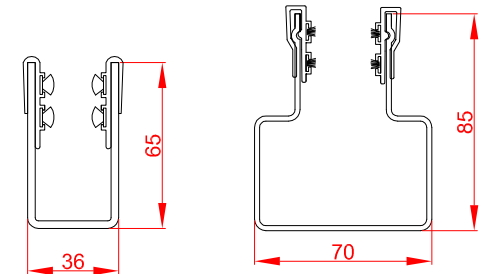

Slat Profile

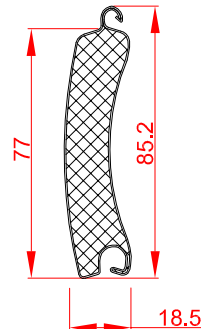

Unit 41, Wombourne Enterprise Park,
 Bridgnorth Road, Wombourne, WV5
 0AL

Phone: 01384 221743

www.ukrollershutters.co.uk